

EU declaration of conformity

We certify that this apparatus conforms to the requirements of the EMC and Low Voltage Directives. Emissions EN 55103-1, susceptibility EN 55103-2 and safety EN 60950-1 2002.

15 July 2005



Warranty

The ISIS Group warrants this unit against defects in materials and workmanship for a period of one year from the date of shipment. At its option, the company will repair or replace products that prove to be defective during the warranty period, provided they are returned to the company with advance notification and with freight prepaid. ISIS Group's policy states that all repairs are only conducted by an authorized representative of the company. As a result any unauthorized repair or attempted repair will automatically void the warranty.

When a distributor supplies the company's products, that distributor should be approached initially if there are any warranty problems.

The company makes no other warranties, express or implied, as to the merchantability, fitness for a particular purpose, or otherwise. The company's liability for any cause, including breach of contract, breach of warranty, or negligence, with respect to products sold by it, is limited to repair or replacement by the company, at its sole discretion. This remedy is exclusive. In no event shall the company be liable for any incidental or consequential damages, including loss of profits.

The ISIS Group
119 E. McKnight Way Grass Valley, CA 95949
Phone: 530-477-2984 Fax: 530-477-2986
Internet: www.isis-group.com Email: info@isis-group.com



MiniBloxTM

**4411 SDI to component analog
monitoring DAC**

*270Mb/s 525/625 SDI input with
RGB/YUV analog outputs*

User Manual

Latest information available at:
www.isis-group.com
www.miniblox.com

Specifications

SDI input

Standards	SMPTE 259M 270Mb/s 525/625 SDI
Connector	75Ω BNC
Signal level	800mV p-p ±10% (terminated)
Return loss	>18dB @270MHz
Cable equalization	Up to 100m automatic (Belden 8281)

Analog outputs

Standards	525/625 line RGB or YUV
Connectors	75Ω BNC
Signal level	1V p-p ±10%
DC offset	±100mV
Cable drive	Up to 800m

Performance

Frequency response	Flat to 5.5MHz, -3dB at ≈ 6MHz
Differential gain	<0.3%
Differential phase	<0.5°
Delay	<10nS
Data path	8-bit 4.2.2
Quantization	10-bit DAC

Power

Voltage	6-12V DC
Current	350mA
Power connector	Locking 2.5mm jack connector (center +v)

Other

LED	Shows power and signal presence
Temperature range	0°C to 45°C
Dimensions	3 1/4" x 2 1/2" x 1 1/8" (excluding connectors)
Weight	6oz

We reserve the right to change technical specifications without prior notice.

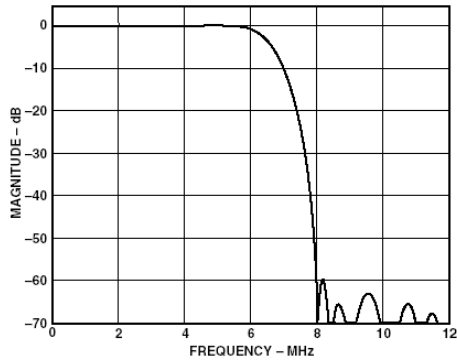

Fig 1 Internal Luminance output filter

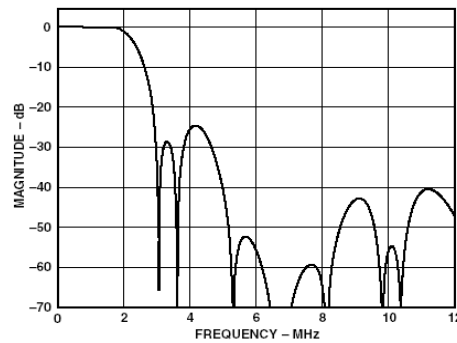

Fig 2 Internal chrominance filter

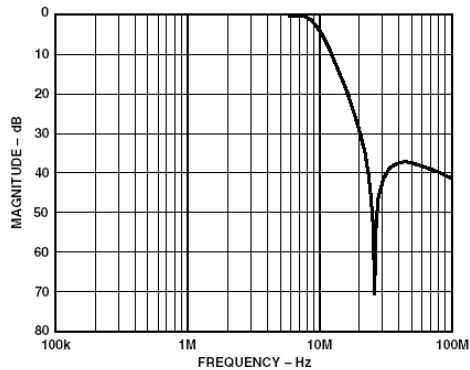
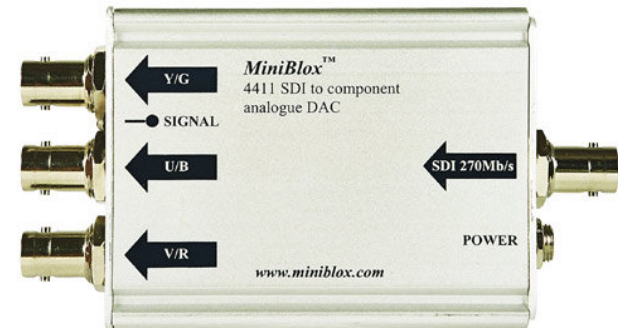

Fig 3 DAC output Filter

MiniBlox™ - solutions in a box

General description

The 4411 is a monitoring quality 270Mb/s SDI to component analog converter. It is housed in an extremely compact and rugged aluminum case ideally suited to both studio and portable applications. Dip switches on the end of the unit control: the input standard, the output format and the addition of pedestal. In addition the final switch controls the output of the built in color bars test pattern.



4411 Main features

- SDI to component analog DAC
- Component RGB & YUV output
- 270Mb/s 525/625 operation
- 10-bit DAC with 8-bit data path
- Pedestal control
- Built in color bar generator
- Compact and rugged design
- Locking connector for PSU

Functional block diagram

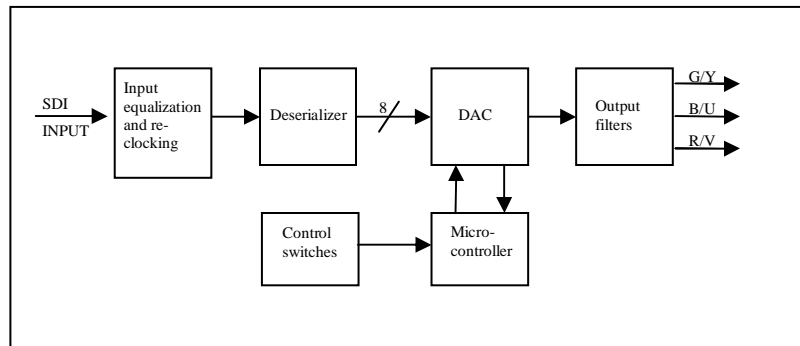

Installation and operation

The 4411 is simple to use and install.

- Set the dipswitches by referring to the table and description below or the table on the rear of the unit.
- Connect a valid 270Mb/s SDI input.
- Connect analog output.
- Apply power to the 4411 unit either via the locking power connector from the 4000 external power supply or by sliding into the 1RU or 2RU rack mounting frame with central power supplies. An alternative power source can be used to power the unit as long as the input power is within the range stated in the specifications.
- The 4-800MB mounting bracket can be used to install a MiniBlox unit. The bracket should first be fixed vertically to any surface. The MiniBlox can then be lowered onto the dovetail part of the bracket with the front endplate uppermost to retain it.
- The LED will be green when there is power and a valid 270Mb/s SDI signal present.
- The switch settings can be altered while the unit is powered and the changes are implemented immediately.

Switch settings

Switch	OFF	ON	Switch	OFF	ON
1	625	525	4	Pedestal	
2	YUV	RGB	5	Not used	
3	Not used		6	Color bars	

The default switch setting on delivery is all switches in the off position.

- Switch 1 sets the input line format. When the switch is on the output will be 525 lines when off the output will be 625 lines. For correct operation of the unit the number of analog lines must match the input SDI format.
- Switch 2 sets the format of the analog component output. When in the on position RGB signals will be present on the output. When in the off position YUV signals will be present on the output.
- Switch 3 is unused on the 4411 unit.
- Switch 4 controls the addition of a 7.5 IRE pedestal on the output signal. When in the off position there is no pedestal added to the outputs. When the switch is in the on position a 7.5 IRE pedestal is added to the analog outputs.
- Switch 5 is unused on the 4411 unit.
- Switch 6 controls the output of the color bar test pattern. When in the off position the converted signal will be present on the outputs. When in the on position the internal color bars signal will be present on the 4411 outputs. To ensure correct operation of this feature a valid 270 Mb/s SDI signal must be applied to the input.

Technical information and specifications

The 4411 uses a 10-bit DAC with an 8-bit data path.

The following graphs show the filters that are applied to the analog output signals on the 4411.

Figure 1 shows the internal Luminance filter on the DAC which has a -3dB cut off at ≈ 6 MHz.

Figure 2 shows the internal chrominance filter on the DAC which has a -3dB cut off at ≈ 2 MHz.

The internal filters are set by the control software and are selected to meet most users' requirements. If different internal filters are required the unit can be modified for a small fee. Please contact your supplier for details.

Figure 3 shows the external output filter response implemented before the outputs. This filter has a -3dB cut off at ≈ 9 MHz.