

EU declaration of conformity

We certify that this apparatus conforms to the requirements of the EMC and Low Voltage Directives. Emissions EN 55103-1, susceptibility EN 55103-2 and safety EN 60950-1 2002.

2 February 2004



Warranty

The ISIS Group warrants this unit against defects in materials and workmanship for a period of one year from the date of shipment. At its option, the company will repair or replace products that prove to be defective during the warranty period, provided they are returned to the company with advance notification and with freight prepaid. ISIS Group's policy states that all repairs are only conducted by an authorized representative of the company. As a result any unauthorized repair or attempted repair will automatically void the warranty.

When a distributor supplies the company's products, that distributor should be approached initially if there are any warranty problems.

The company makes no other warranties, express or implied, as to the merchantability, fitness for a particular purpose, or otherwise. The company's liability for any cause, including breach of contract, breach of warranty, or negligence, with respect to products sold by it, is limited to repair or replacement by the company, at its sole discretion. This remedy is exclusive. In no event shall the company be liable for any incidental or consequential damages, including loss of profits.

The ISIS Group P.O. Box 7 Nevada City, CA 95959
Phone: 530-477-2984 Fax: 530-477-2986
Internet: isis-group.com Email: info@isis-group.com



MiniBlox™

4461A SDI analog audio embedder

*Inserts two balanced analog audio stereo pairs into
any group within a 270Mb/s 525/625 SDI signal*

Preliminary User Manual

Latest information available at:
www.isis-group.com
www.miniblox.com

SDI input

Standards	SMPTE 259M 270Mb/s 525/625 SDI
Connector	75Ω BNC
Signal Level	800mV p-p ±10% (terminated)
Return loss	>15dB @270MHz
Cable equalization	Up to 150m automatic (Belden 8281)

SDI output

Standards	SMPTE 259M 270Mb/s 525/625 SDI
Connector	75Ω BNC
Signal level	1V p-p ±10% (terminated)
DC offset	±100mV
Return loss	>15dB @270MHz

Analog input

Standard	Balanced analog
Number	2 stereo pairs
Quantization	24 bit
Connector	Removable screw terminal
Impedance	20KΩ
Level	Max 0dBFS=+28dBu/ Min 0dBFS=+12dBu

Audio embedding

Standard	SMPTE 272M
Resolution	20 or 24 bit

Power

Voltage	6-12V DC
Current	800mA
Power connector	Locking 2.5mm jack connector (center +v)

Other

LEDs	Show power, signal presence & embedding status
Temperature range	0°C to 45°C
Dimensions	3 1/4" x 2 1/2" x 1 1/8" (excluding connectors)
Weight	9oz

We reserve the right to change technical specifications without prior notice.

Custom level select mode

To meet all international analog audio full scale input levels, the 4461A has a custom analog input level select mode. In this mode it is possible to select any input level between 12dBu and 28dBu in 0.5dBu increments. The default value of the custom level on delivery is 20dBu. Once the value of the custom level is altered it will remain stored in memory until changed again.

To set the analog input level:-

- Activate switch 6, once this has been on for more than six seconds the unit will enter custom level select mode. This can be verified by all four group LEDs on the front of the box flashing red.
- Switch 1-5 will now set the expected analog input level as per the table below.
- To exit the custom level select mode deactivate switch 6, the value on switches 1-5 will be stored in memory. It will be necessary to reset switches 1-5 to the desired settings for normal use.

Switch 1	Switch2	Switch3	Switch 4	Switch 5	Level
0	0	0	0	0	12dBu
0	0	0	0	1	12.5dBu
0	0	0	1	0	13dBu
0	0	0	1	1	13.5dBu
0	0	1	0	0	14dBu
0	0	1	0	1	14.5dBu
↓	↓	↓	↓	↓	↓
↓	↓	↓	↓	↓	↓
1	1	0	1	0	25.5dBu
1	1	0	1	1	26dBu
1	1	1	0	0	26.5dBu
1	1	1	0	1	27dBu
1	1	1	1	0	27.5dBu
1	1	1	1	1	28dBu

MiniBlox™ - solutions in a box

General description

The 4461 SDI balanced analog audio embedder embeds two balanced stereo audio pairs into the ancillary data space of a 270Mb SDI signal. The input audio can be embedded as 20 or 24 bit audio. Embedding conforms to SMPTE 272M and allows audio to be inserted into any of the four groups. Existing audio groups can be added to or completely removed. There is automatic cable equalization and a re-clocked SDI output.

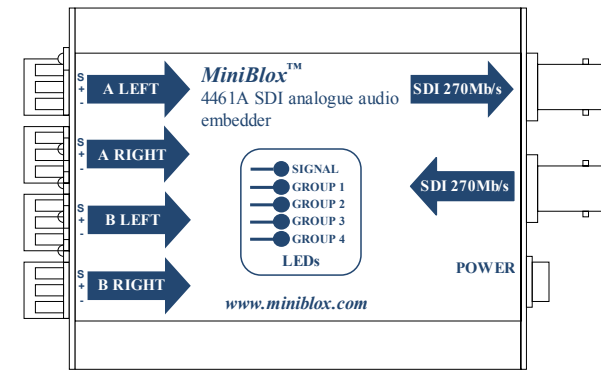

4461A Main features

- Inserts two balanced analog audio stereo pairs into any group
- High quality 24 bit audio ADC
- Replaces or adds to existing audio
- Selectable 20 or 24 bit embedding
- Adjustable full scale input levels to meet all international standards
- LEDs show group status and input signal presence
- Automatic input cable equalization up to 150m
- Extremely compact and rugged

Functional block diagram

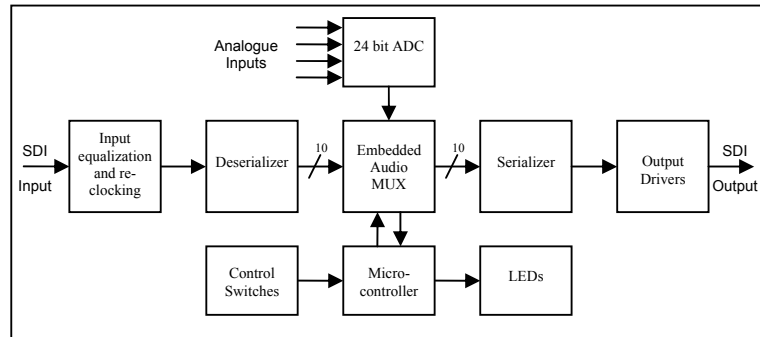

Installation and operation

The 4461A is simple to use and install.

- Set the dipswitches by referring to the table and description below or the table on the rear of the unit.
- Connect a valid 270Mb/s SDI input and analog audio inputs.
- Connect SDI output.
- Apply power to the 4461A unit either via the locking power connector from the 4000 external power supply or by sliding into the 1RU or 2RU rack mounting frame with central power supplies. An alternative power source can be used to power the unit as long as the input power is within the range stated in the specifications.
- On power-up the 4461A will perform a short (3 second) self test. The group LEDs will flash green while this is in progress.
- The signal LED will be green when there is power and a valid 270Mb/s SDI signal present or red when there is power but no SDI signal.
- One of the group LEDs will light corresponding to the group selected by the switches. This LED will be green if the unit is receiving a valid video signal and successfully embedding audio. The LED will otherwise be red.
- The switch settings can be altered while the unit is powered and the changes are implemented immediately.

- The 4-800MB mounting bracket can be used to install a MiniBlox unit. The bracket should first be fixed vertically to any surface. The MiniBlox can then be lowered onto the dovetail part of the bracket with the front endplate uppermost to retain it.

Switch settings

Switch	1	2	Switch	OFF	ON
Group 1	OFF	OFF	3	Cascade	Overwrite
Group 2	OFF	ON	4	24-bit	20-bit
Group 3	ON	OFF	5	625 lines	525 lines
Group 4	ON	ON	6	Toggle level	

- Switches 1 & 2 set the group into which audio packets are inserted.
- Switch 3 determines whether existing audio packets are deleted from the video signal. When the switch is off, new audio packets are appended without deletion of existing packets allowing up to four 4461 units to be connected in cascade.
- Switch 4 controls the bit depth of the embedded audio. When the switch is off, extended audio packets are multiplexed into the video signal (24 bit audio). When the switch is on, extended audio packets are not included (20 bit audio).
- Switch 5 sets the video standard. For correct operation of the unit this must match the format of the SDI input.
- Switch 6 controls the analog level of the input; three levels are available 18dBu, 24dBu and a custom setting (default on delivery 20dBu). These levels are toggled through by activating and immediately deactivating the switch. The group LEDs will flash for two seconds as per the table below indicating the operating analogue audio input level.

Level	LEDs
18dB	Group 1 flash red with group 2,3&4 green
24dB	Group 2 flash red with group 1,3&4 green
Custom	Group 3 flash red with group 1,2&4 green

If switch 6 is left on for more than six seconds the unit will enter custom level select mode – all group LEDs will flash red while the unit is in this mode.