

EU declaration of conformity

We certify that this apparatus conforms to the requirements of the EMC and Low Voltage Directives. Emissions EN 55103-1, susceptibility EN 55103-2 and safety EN 60950-1 2002.

2 February 2004



Warranty

The ISIS Group warrants this unit against defects in materials and workmanship for a period of one year from the date of shipment. At its option, the company will repair or replace products that prove to be defective during the warranty period, provided they are returned to the company with advance notification and with freight prepaid. ISIS Group's policy states that all repairs are only conducted by an authorized representative of the company. As a result any unauthorized repair or attempted repair will automatically void the warranty.

When a distributor supplies the company's products, that distributor should be approached initially if there are any warranty problems.

The company makes no other warranties, express or implied, as to the merchantability, fitness for a particular purpose, or otherwise. The company's liability for any cause, including breach of contract, breach of warranty, or negligence, with respect to products sold by it, is limited to repair or replacement by the company, at its sole discretion. This remedy is exclusive. In no event shall the company be liable for any incidental or consequential damages, including loss of profits.

The ISIS Group P.O. Box 7 Nevada City, CA 95959
Phone: 530-477-2984 Fax: 530-477-2986
Internet: www.isis-group.com Email: info@isis-group.com



MiniBloxTM

**4461DB SDI balanced AES-EBU audio
embedder**

*Inserts two balanced AES-EBU digital audio streams into
any group within a 270Mb/s 525/625 SDI signal*

User Manual

Latest information available at:

www.isis-group.com
www.miniblox.com

Specifications

SDI input

Standards	SMPTE 259M 270Mb/s 525/625 SDI
Connector	75Ω BNC
Signal Level	800mV p-p ±10% (terminated)
Return loss	>15dB @270MHz
Cable equalization	Up to 150m automatic (Belden 8281)

SDI output

Standards	SMPTE 259M 270Mb/s 525/625 SDI
Connector	75Ω BNC
Signal level	1V p-p ±10% (terminated)
DC offset	±100mV
Return loss	>15dB @270MHz

AES-EBU input

Standard	Balanced AES-EBU AES3-1992
Number	2
Type	Transformer-coupled
Connector	Removable screw terminal
Termination	Balanced 110Ω
Level	0.2-10V p-p
Sample rate	48KHz (synchronized to video)

Audio embedding

Standard	SMPTE 272M
Resolution	20 or 24 bit

Power

Voltage	6-12V DC
Current	500mA
Power connector	Locking 2.5mm jack connector (center +v)

Other

LEDs	Show power, signal presence & embedding status
Temperature range	0°C to 45°C
Dimensions	3 1/4" x 2 1/2" x 1 1/8" (excluding connectors)
Weight	9oz

We reserve the right to change technical specifications without prior notice.

MiniBlox™ - solutions in a box

General description

The 4461 SDI balanced AES-EBU audio embedder embeds two balanced stereo AES-EBU signal into the ancillary data space of a 270Mb SDI signal. The input stream can be embedded as 20 or 24 bit audio. Embedding conforms to SMPTE 272M and allows audio to be inserted into any of the four groups. Existing audio groups can be added to or completely removed. The audio must be synchronous with the video. There is automatic cable equalization and re-clocked SDI output.

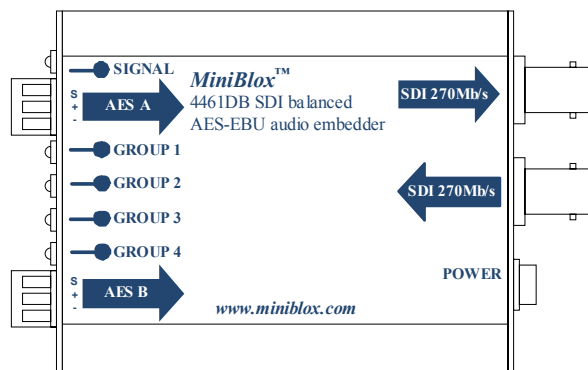

4461DB Main features

- Inserts two synchronous balanced AES-EBU stereo pairs into any group
- Replaces or adds to existing audio
- Selectable 20 or 24 bit embedding
- LEDs show group status and input signal presence
- Automatic input cable equalization up to 150m
- Re-clocked SDI output
- Extremely compact and rugged design
- Locking connector for PSU

Functional block diagram

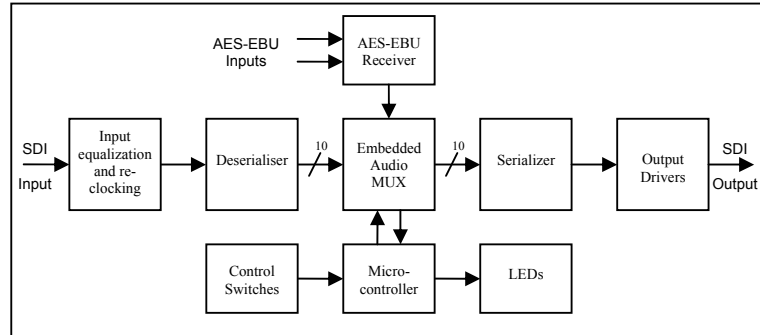

Installation and operation

The 4461DB is simple to use and install.

- Set the dipswitches by referring to the table and description below or the table on the rear of the unit.
- Connect a valid 270Mb/s SDI input and valid AES-EBU inputs.
- Connect SDI output.
- Apply power to the 4461DB unit either via the locking power connector from the 4000 external power supply or by sliding into the 1RU or 2RU rack mounting frame with central power supplies. An alternative power source can be used to power the unit as long as the input power is within the range stated in the specifications.
- On power-up the 4461DB will perform a short (3 second) self-test. The group LEDs will flash while this is in progress.
- The signal LED will be green when there is power and a valid 270Mb/s SDI signal present or red when there is power but no SDI signal.
- One of the group LEDs will light corresponding to the group selected by the switches. This LED will be green if the unit is receiving a valid video signal and successfully embedding audio. The LED will otherwise be red.

The switch settings can be altered while the unit is powered and the

- changes are implemented immediately.
- The 4-800MB mounting bracket can be used to install a MiniBlox unit. The bracket should first be fixed vertically to any surface. The MiniBlox can then be lowered onto the dovetail part of the bracket with the front endplate uppermost to retain it.

Switch settings

Switch	1	2	Switch	OFF	ON
Group 1	OFF	OFF	3	Cascade	Overwrite
Group 2	OFF	ON	4	24-bit	20-bit
Group 3	ON	OFF	5	Pass EDH	New EDH
Group 4	ON	ON	6	625 lines	525 lines

- Switches 1 & 2 set the group into which audio packets are inserted.
- Switch 3 determines whether existing audio packets are deleted from the video signal. When the switch is off, new audio packets are appended without deletion of existing packets allowing up to four 4461 units to be connected in cascade.
- Switch 4 controls the bit depth of the embedded audio. When the switch is off, extended audio packets are multiplexed into the video signal (24 bit audio). When the switch is on, extended audio packets are not included (20 bit audio).
- Switch 5 controls whether new EDH data is calculated. When the switch is off, EDH packets are passed through unchanged. When the switch is on, active picture and full field EDH data words are updated from recalculated values according to SMPTE RP165.
- Switch 6 sets the video standard. For correct operation of the unit this must match the format of the SDI input.