

EU declaration of conformity

We certify that this apparatus conforms to the requirements of the EMC and Low Voltage Directives. Emissions EN 55103-1, susceptibility EN 55103-2 and safety EN 60950-1 2002.

18 November 2005



Warranty

The ISIS Group warrants this unit against defects in materials and workmanship for a period of one year from the date of shipment. At its option, the company will repair or replace products that prove to be defective during the warranty period, provided they are returned to the company with advance notification and with freight prepaid. ISIS Group's policy states that all repairs are only conducted by an authorized representative of the company. As a result any unauthorized repair or attempted repair will automatically void the warranty.

When a distributor supplies the company's products, that distributor should be approached initially if there are any warranty problems.

The company makes no other warranties, express or implied, as to the merchantability, fitness for a particular purpose, or otherwise. The company's liability for any cause, including breach of contract, breach of warranty, or negligence, with respect to products sold by it, is limited to repair or replacement by the company, at its sole discretion. This remedy is exclusive. In no event shall the company be liable for any incidental or consequential damages, including loss of profits.



MiniBlox™

4461DU+ SDI unbalanced AES/EBU audio embedder with sample rate converter

*Inserts two unbalanced AES-EBU digital audio streams into any
group within a 270Mb/s 525/625 SDI signal*

User Manual

The ISIS Group
119 E. McKnight Way Grass Valley, CA 95949
Phone: 530-477-2984 Fax: 530-477-2986
Internet: www.isis-group.com Email: info@isis-group.com

Latest information available at:
www.isis-group.com
www.miniblox.com

Specifications

SDI input

Standards	SMPTE 259M 270Mb/s 525/625 SDI
Connector	75Ω BNC
Signal level	800mV p-p ±10% (terminated)
Return loss	>15dB to 270MHz
Cable equalization	>350m automatic (Belden 8281)

SDI output

Standards	SMPTE 259M 270Mb/s 525/625 SDI
Connector	75Ω BNC
Signal level	800mV p-p ±10% (terminated)
DC offset	±100mV
Return loss	>18dB to 270MHz

AES-EBU input

Standard	Unbalanced AES-EBU AES3id , SMPTE 276M
Number	2
Type	Transformer-coupled
Connector	75Ω BNC
Termination	Unbalanced 75Ω
Level	0.2–10V p-p
Sample rate	48KHz synchronous or 32 – 96KHz asynchronous

Audio Embedding

Standard	SMPTE 272M
Resolution	20 or 24 bit

Power

Voltage	6-12V DC
Current	440mA @ 6V
Power connector	Locking 2.5mm jack connector (center +v)

Other

LED	Show power, signal presence & embedding status
Temperature range	0°C to 45°C
Dimensions	3 1/4" x 2 1/2" x 1 1/8" (excluding connectors)
Weight	9oz

We reserve the right to change technical specifications without prior notice.

MiniBlox™ - solutions in a box

General description

The 4461DU+ SDI unbalanced AES-EBU audio embedder with sample rate converter inserts two unbalanced stereo AES-EBU streams into the ancillary data space of a 270Mb SDI signal. The input stream can be embedded as 20 or 24 bit audio. Internal audio sample rate converters allow the applied audio to be of any sample rate between 32 and 96KHz. The sample rate conversion may be bypassed to allow for non-PCM audio streams. Embedding conforms to SMPTE 272M and allows audio to be inserted into any of the four groups. Existing audio groups can be added to or completely removed. There is automatic cable equalization and re-clocked SDI output.



4461DU+ Main features

- Inserts two asynchronous unbalanced AES-EBU stereo pairs into any group
- Supports all audio sample rates from 32 to 96KHz
- Inserts digital silence when audio signals are not present
- Replaces or adds to existing audio
- Automatic detection of 525/625 SDI
- Selectable 20 or 24 bit embedding
- LEDs show group status and input signal presence
- Automatic input cable equalization over 350m
- Re-clocked SDI output
- Extremely compact and rugged design
- Locking connector for PSU

Functional block diagram

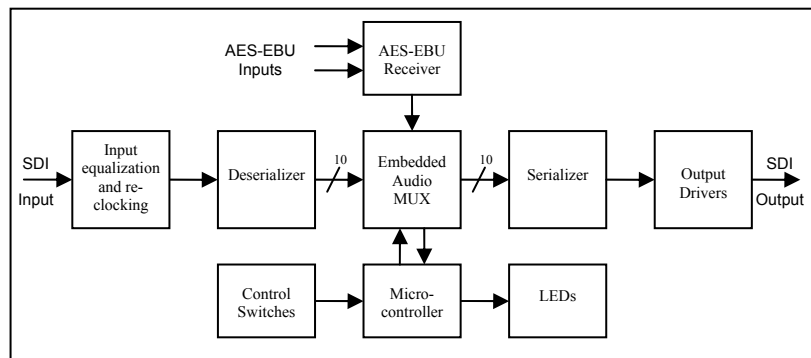

Installation and operation

The 4461DU+ is simple to use and install.

- Set the dipswitches by referring to the table and description or the table on the rear of the unit.
- Connect a valid 270Mb/s SDI input and valid AES-EBU inputs.
- Connect a valid AES3id signal. (This may be synchronous or asynchronous, and of any sample rate up to 96KHz. If the sample rate converters are bypassed, this must be 48KHz synchronous.)
- Connect SDI output.
- Apply power to the 4461DU+ unit either via the locking power connector from the 4000 external power supply or by sliding into the 1RU or 2RU rack mounting frame with central power supplies. An alternative power source can be used to power the unit as long as the input power is within the range stated in the specifications.
- On power-up the 4461DU+ will perform a short (3 second) self-test. The group LEDs will flash while this is in progress.
- The signal LED will be green when there is power and a valid 270Mb/s SDI signal present or red when there is power but no SDI signal.
- One of the group LEDs will light corresponding to the group selected by the switches. This LED will be green if the unit is receiving a valid video signal and successfully embedding audio. The LED will otherwise be red.
- The switch settings can be altered while the unit is powered and the changes are implemented immediately.

- The 4-800MB mounting bracket can be used to install a MiniBlox unit. The bracket should first be fixed vertically to any surface. The MiniBlox can then be lowered onto the dovetail part of the bracket with the front endplate uppermost to retain it.

Switch settings

Switch	OFF	ON	Switch	OFF	ON
1	Audio Group		4	24 bit	20 bit
2	Update CS	Pass CS	5	Pass EDH	New EDH
3	Cascade	Overwrite	6	SRC On	SRC Bypass

- Switch 1 is used to set the group into which the audio samples are inserted. Toggling switch 1 will cycle through the 4 groups. The group setting is stored in EEPROM and is therefore retained even after the unit is powered down.
- Switch 2 selects whether the audio channel status is updated to reflect the resulting resolution and sample rate of the audio after sample rate conversion. Due to the nature of sample rate conversion, whole C-bit and U-bit data blocks may be dropped or repeated depending on the sample rate of the incoming audio. Switch 2 has no effect when the sample rate converters are bypassed.
- Switch 3 determines whether existing audio packets are deleted from the video signal. When the switch is off, new audio packets are appended without deletion of existing packets allowing up to four units to be connected in cascade.
- Switch 4 controls the resolution of the embedded audio. When the switch is off, extended audio packets are multiplexed into the video signal (24 bit audio). When the switch is on, extended audio packets are not included (20 bit audio).
- Switch 5 selects between the unit passing through any EDH data unaltered or generating new EDH data.
- Switch 6 is used to bypass the sample rate conversion.