



ADA-101R

**Remote Gain Audio
Distribution Amplifier**



Statement of Warranty

The ISIS Group, Inc. warrants its products for a period of seven (7) years from the date of shipment to be free from defects in materials and workmanship and meets applicable published specifications. Equipment which has been operated within its ratings and has not been subjected to mechanical or other abuse or modification by the purchaser, its agents, and/or employees, will, at the option of The ISIS Group, be replaced or repaired if it is returned, freight prepaid, to ISIS. Equipment that fails under conditions other than described herein will be repaired at the price of components and labor in affect at the time of repair.

This warranty is in lieu of all other warranties, expressed or implied, with respect to the condition or performance of any ISIS Group product, its merchantability or fitness for a particular purpose. ISIS is not liable for any consequential damages.

FCC Compliance

This equipment has been tested and found to comply with the limits for a Class A digital device pursuant to Part 15 of the FCC Rules. These limits are designed to provide reasonable protection against harmful interference when the equipment is operated in a commercial environment. This equipment generates, uses, and can radiate radio frequency energy and, if not installed and used in accordance with the instruction manual, may cause harmful interference to radio communications. Operation of this equipment in a residential area is likely to cause harmful interference in which case the user will be required to correct the interference at his own expense.

Copyright

© 2005 The ISIS Group, INC.

Contents of this publication may not be reproduced in any form without the written permission of The ISIS Group. Reproduction or reverse engineering of copyrighted software is prohibited. The information in this manual is subject to change without notice or obligation.

January 2006

Part Number 71-0025

Installation and Operation Manual

CONTENTS

SECTION I	GENERAL DESCRIPTION	Page 2
SECTION II	SPECIFICATIONS	Page 3
SECTION III	INSTALLATION	Page 4
SECTION IV	CIRCUIT DESCRIPTION	Page 6
SECTION VI	DIAGRAMS	Page 7

SECTION I
ADA-101/R
General Description

The ADA-101/R is a modular, high performance audio distribution amplifier intended for studio quality audio distribution systems. It is designed to be operated from the ISIS AMF-100 mounting frame, or it is pin-compatible with the Leitch* FR-883/884 audio mounting frames.

The module can be configured as a one-input by six-output monaural, or as two, one-input by three-output stereo amplifiers, just by moving one internal jumper. In the MONO mode only the *Channel A* input connector is used. The *Channel B* input is left unconnected.

All inputs can be connected balanced or unbalanced. Outputs are always balanced. The unit offers a ± 20 dB remotely controlled audio gain, which is selectable to either remote or local operation.

Each module has its own on-board voltage regulators with fuse protection. Any failure of a single module will not affect any other.

*Leitch is a trademark of Leitch Technology International, Inc.

SECTION II

ADA-101/R

Specifications

Input:

Number	2, Channel A and Channel B, (Channel A used for mono)
Impedance	>30K Ω balanced, >12K Ω unbalanced
Maximum level	+30dBu (66 Ω), +24dBm (600 Ω)
Common Mode Rejection (CMRR)	>90dB @60Hz, >60dB @ 20KHz
Common Mode Range	\pm 20volts

Outputs:

Channels	1 (mono) or 2 (stereo)
Outputs per channel	3 balanced stereo, 6 balanced monaural
Impedance	66 Ω balanced or 600 Ω balanced
Maximum Level	+30dBu (66 Ω), +24dBm (600 Ω)

Remote Gain:

Control	local/remote switch selectable
Type	DC control
Range	\pm 20dB

Performance: (each channel).

Gain range	\pm 20dB
Frequency Response	\pm 0.05dB, 20Hz to 20KHz, ref. 1KHz any level to +30dBu (66 Ω), +24dBm (600 Ω)
Total Harmonic Distortion, (THD)	<0.05%, 20Hz to 20KHz @ +30dBu (66 Ω), +24dBm (600 Ω)
Intermodulation Distortion, (IMD)	<0.02% 4:1 SMPTE @18dBu (66 Ω), +18dBm (600 Ω)
Isolation between Modules	>100dB, 20Hz - 20KHz
Interchannel Crosstalk	>95dB, 20Hz - 20KHz
Power Dissipation	<2.5W

SECTION III

ADA-101/R

Installation and Operation

The ADA-101/R audio distribution amplifier is designed to be mounted in either the ISIS AMF-100 audio mounting frame, (up to twelve modules), or a Leitch* audio frame (such as the FR-883 or FR-884). There are no special cooling requirements, although care should be taken to ensure that extremely hot equipment is not installed directly beneath the frame.

It is recommended that when redundant power supplies are included in the frame, the two power cords be connected to different AC supplies. In this way the frame will continue to operate even if there is a partial failure of plant power.

Before installing the module in the frame, it is necessary to set the internal jumper H2 to either MONO or STEREO mode. Also the switch S1 must be set for either local or remote gain control.

The frame input and output connections are similar for both the ISIS and the Leitch* frames. They consist of three-pin terminal blocks as defined below:

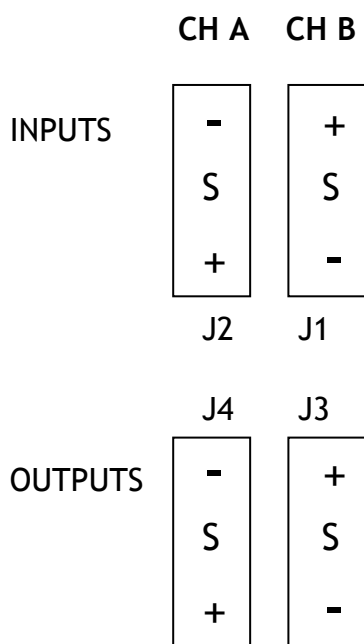

The ADA-101/R is capable of remote gain control operation. Placing the toggle switch on the module in the REMOTE position will allow adjustment of the amplifier gain from an external 10K potentiometer. The connection of the pot is accomplished by utilizing the lowest most output connector for channel B on the particular input/output group on the AMF-100 mounting frame. The connections are as follows:

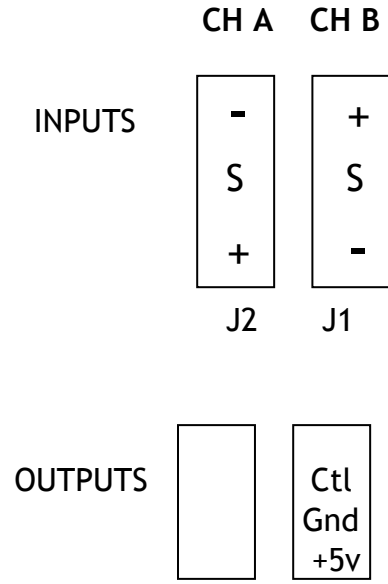

SECTION IV

ADA-101/R

Circuit Description

The ADA-101/R consists of two identical input circuits and two identical groups of three output circuits. A jumper (H1) permits the two output channels to be both connected to one input channel for use as a one input, six output monaural amplifier or as a two channel, three output per channel stereo amplifier. Since both input amplifiers are the same only the A channel will be described. The differential input signal is applied to the inverting inputs of U3:A and U3:B. An inverted version of the common mode signal (if any) is also applied to these inputs from U7:A such as to cancel any common mode component at the outputs of U3:A and U3:B. The outputs from U3:A and U3:B are then applied to the differential amplifier, U7:B. Optimum common mode balance is achieved by adjusting RV6 at the output of U7:A.

The output from the differential amplifier passes via the gain control potentiometer, RV1, to the variable gain amplifier, U6. U5:A inverts the second input to U6. U6 provides gain adjustment under control of the front adjustment potentiometer, RV5, or via a remote control voltage from the rear panel (output B4). The variable gain amplifiers in each channel are controlled by the same control voltage from U15. The circuitry associated with U15 scales the control voltage and also provides temperature compensation for U6. The balance potentiometer, RV2, is not used with the "T" version of the SSM2018.

The output from U6 is connected to the first group of four output amplifiers and also to the MONO/STEREO selector, H1. U4:A provides the un-inverted signal to the non-inverting output drivers, while U4:B provides an inverted signal to the inverted output drivers. The A channel drivers are contained in U1 and U12 while the B channel drivers are contained in U2 and U13. U4:C and U4:D provide the input to the B channel output drivers.

The input and gain stages are powered from $\pm 15V$ supplies provided by VR1 and VR2.

The output drivers are powered directly from the $\pm 21V$ supplies.

SECTION V
ADA-101/R
Diagrams

ADA-101/R AUDIO DISTRIBUTION AMPLIFIER

PS-102 AUDIO POWER SUPPLY

ADA-101/R PIN ASSIGNMENTS

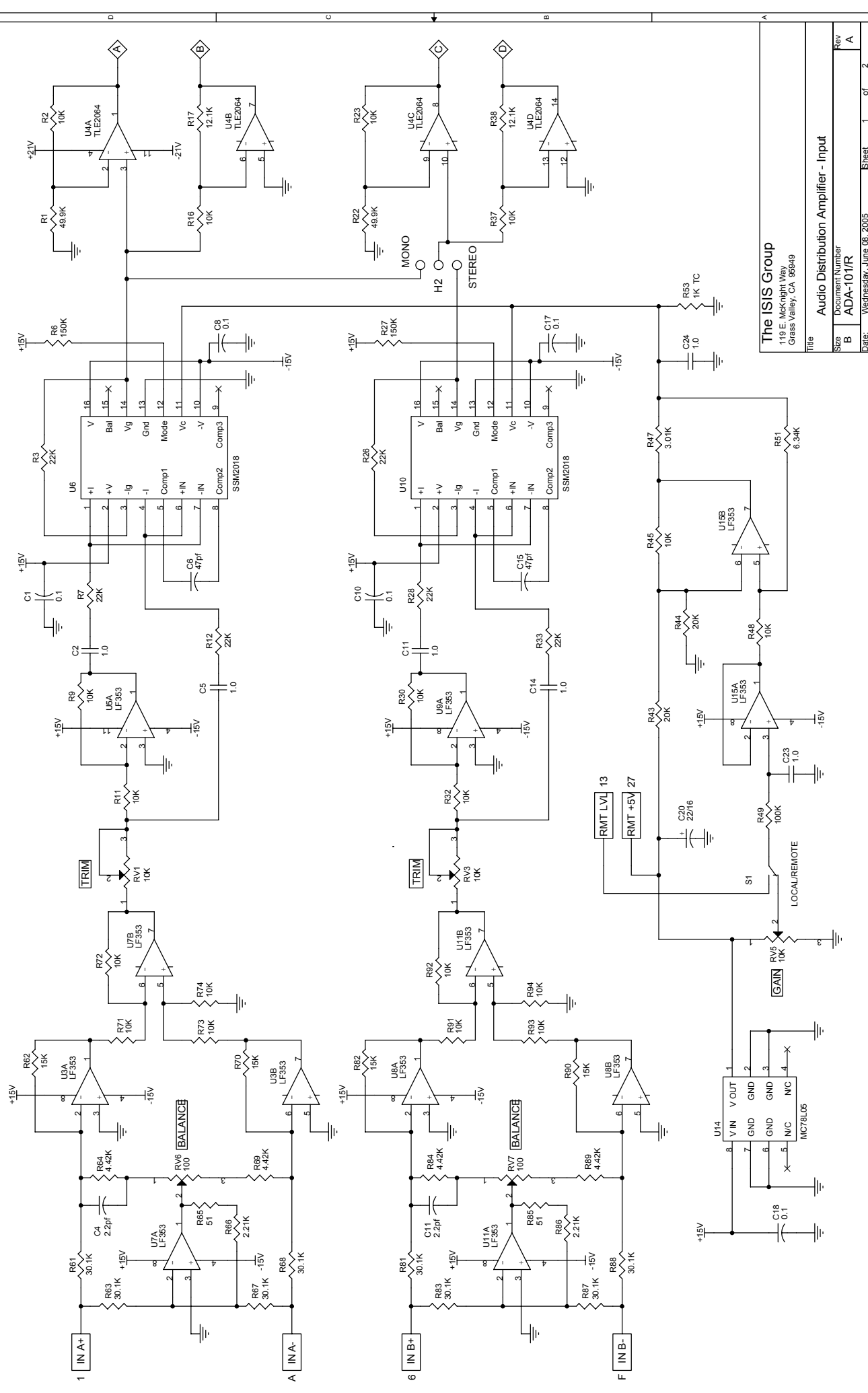

The ISIS Group
 119 E. McKnight Way
 Grass Valley, CA 95949

Title	Audio Distribution Amplifier - Input
Size	Document Number
B	ADA-101/R
Date:	Wednesday, June 06, 2005

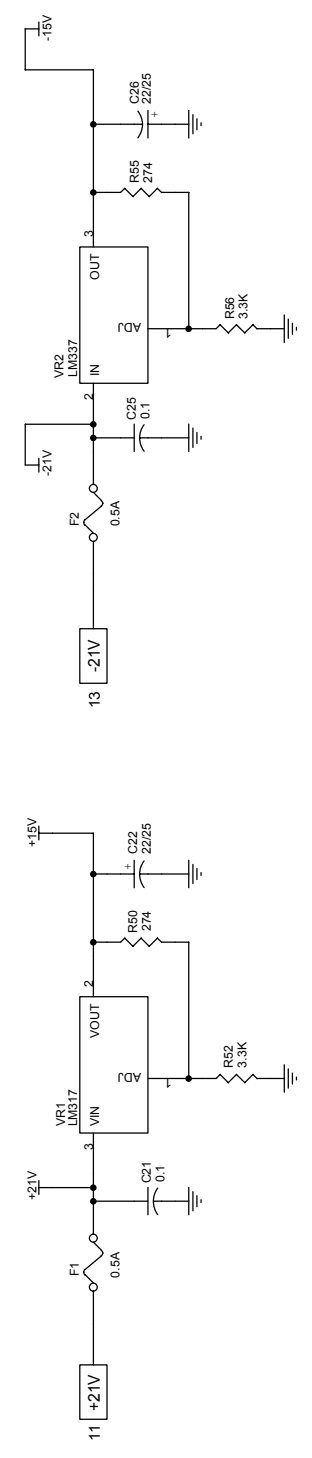
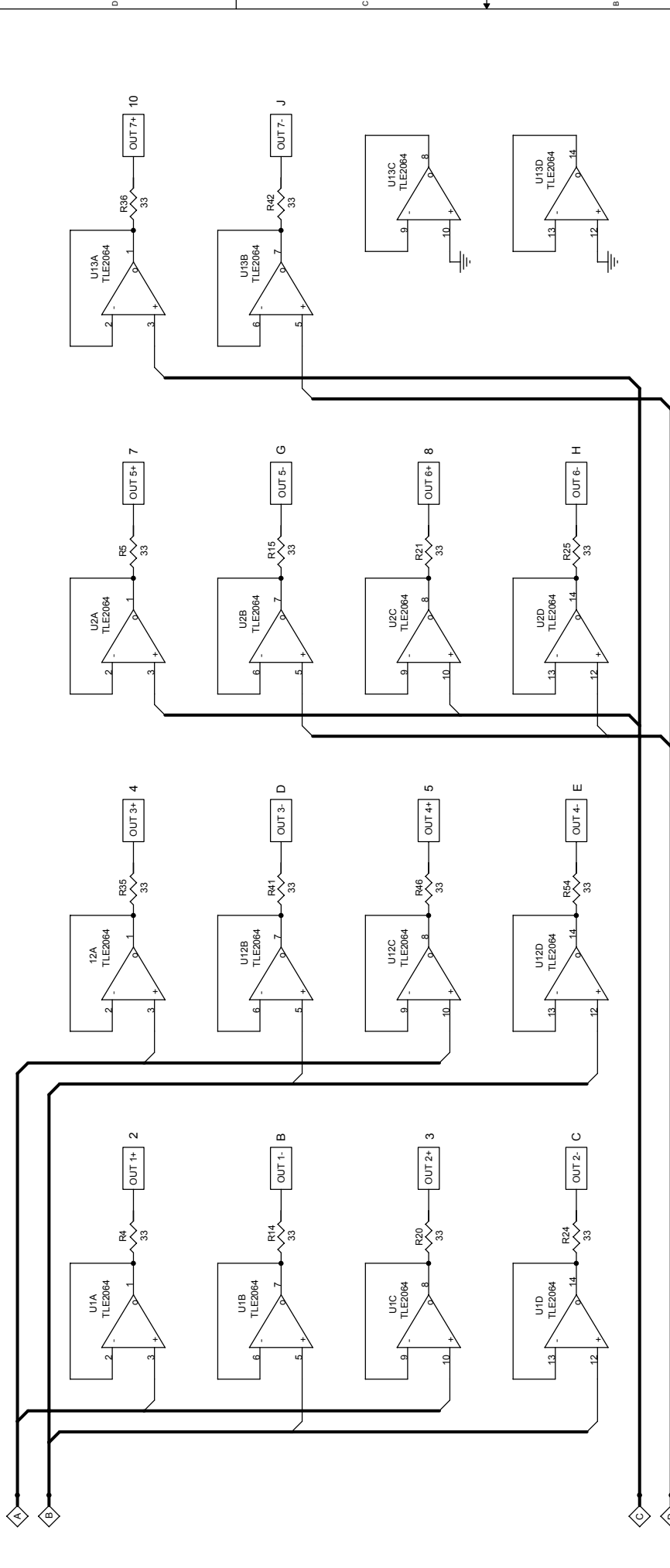

The ISIS Group
P.O. Box 7
Nevada City, CA 95969

Title		Audio Distribution Amplifier - Outputs	
Size	Document Number	Rev	
B	ADA-101/R	A	
Date:	Wednesday, June 06, 2005	Sheet	2 of 2

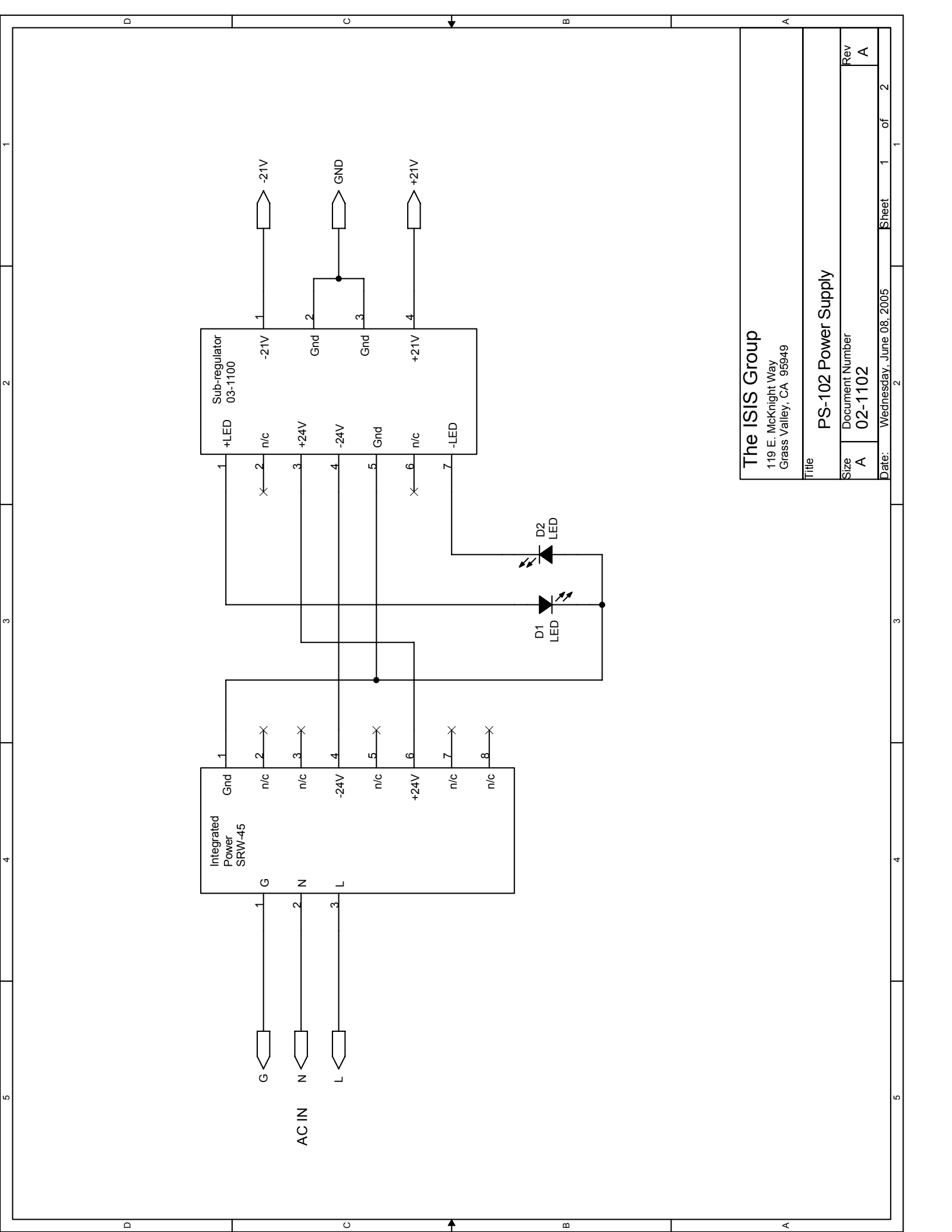

The ISIS Group
 119 E. McKnight Way
 Grass Valley, CA 95949

Title	
PS-102 Power Supply	
Size	Document Number
A	02-1102
Date:	Wednesday, June 08, 2005
Sheet	1 of 2

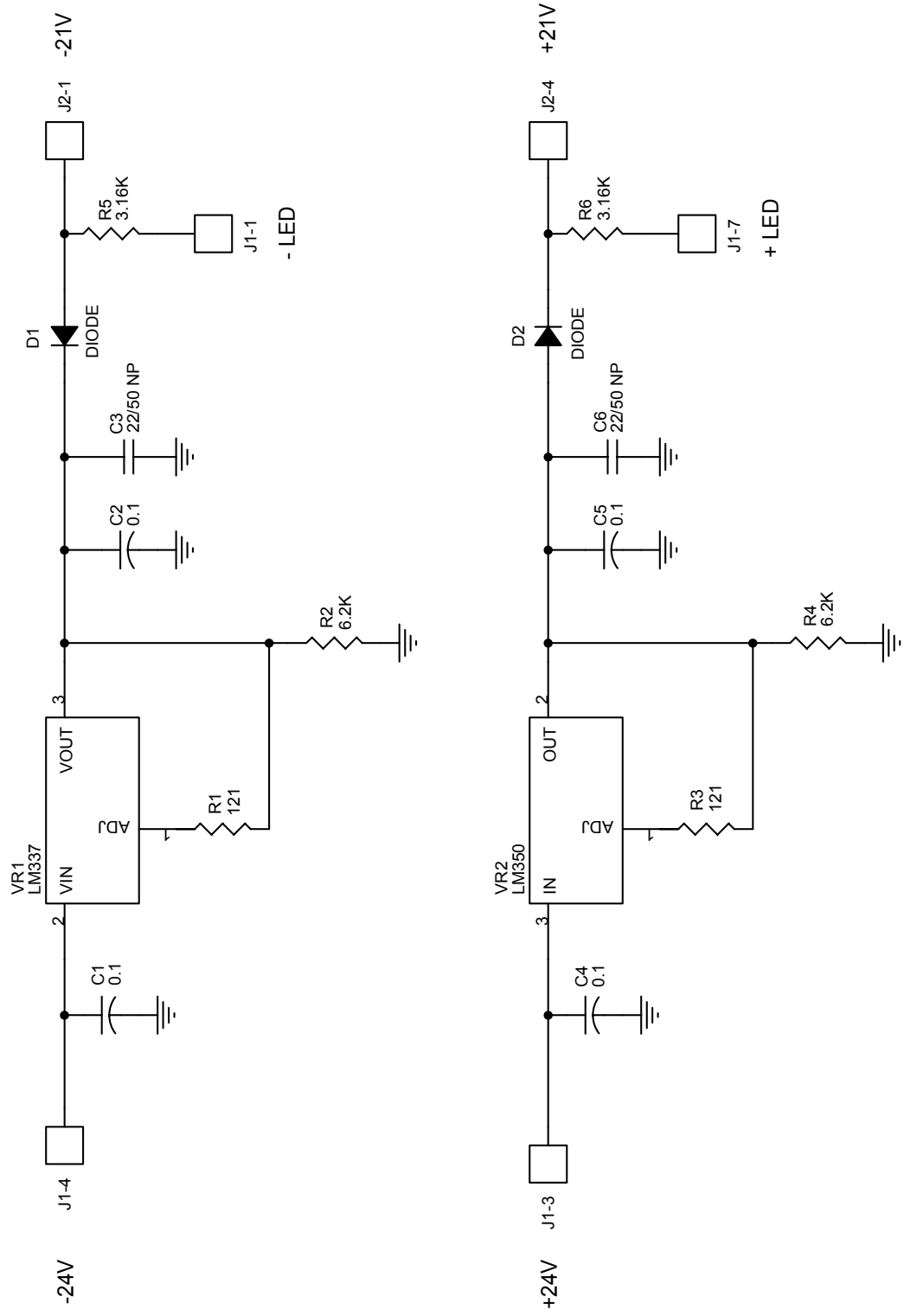

The ISIS Group
 119 E. McKnight Way
 Grass Valley, CA 95949

Title	
PS-102 Sub-regulator	
Size	Document Number
A	03-1100
Date:	Wednesday, June 08, 2005
Sheet	2 of 2

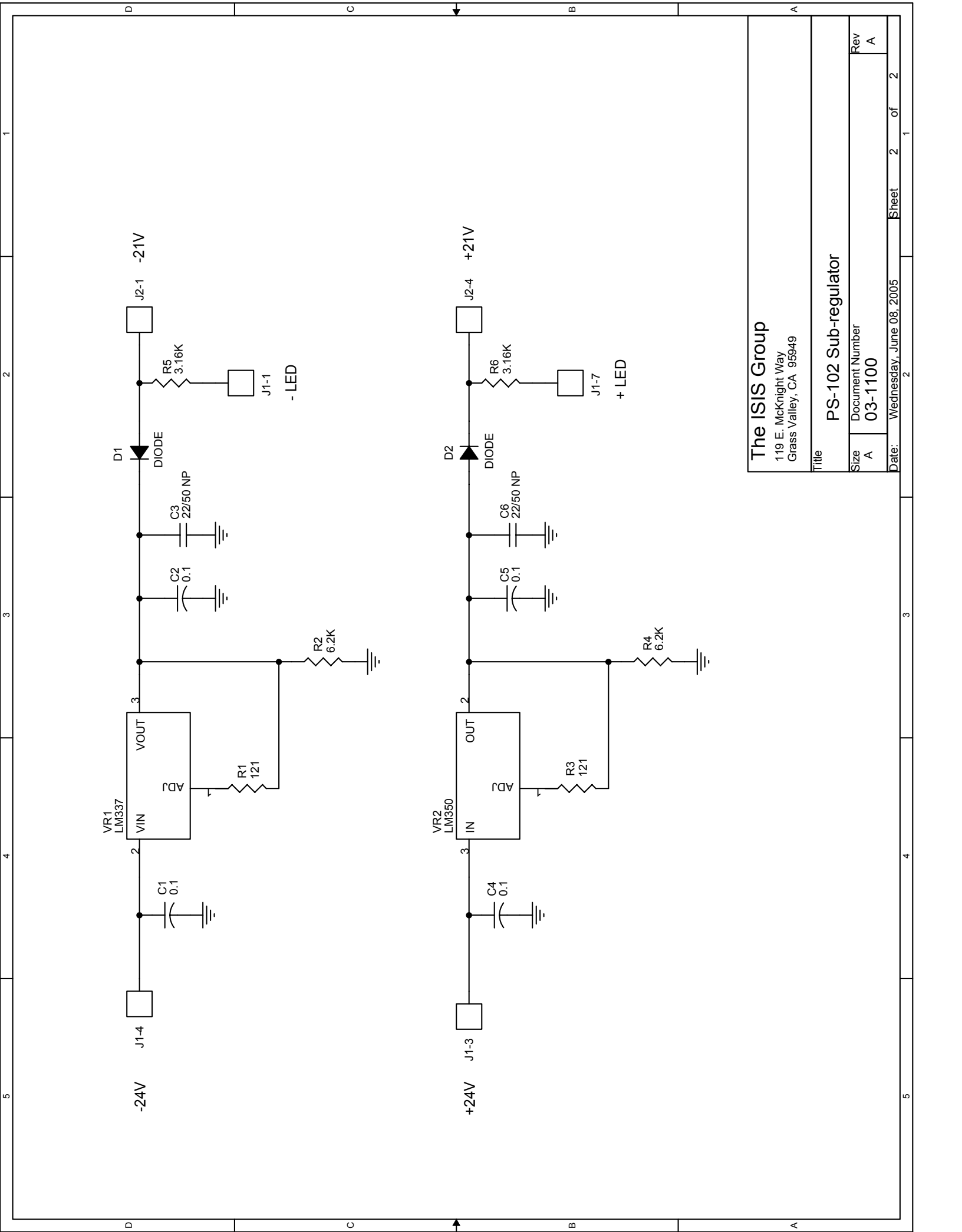

PIN ASSIGNMENTS
ADA-101/R
Audio Distribution Amplifier

INPUT A -.....A	1....INPUT A+
OUTPUT 1 -.....B	2....OUTPUT 1+
OUTPUT 2 -.....C	3....OUTPUT 2+
OUTPUT 3 -.....D	4....OUTPUT 3+
OUTPUT 4 -.....E	5....OUTPUT 4+
INPUT B -.....F	6....INPUT B+
OUTPUT 5 -.....G	7....OUTPUT 5+
N.C.....H	8....OUTPUT 6+
N.C.....I	9....GND
OUTPUT 6 -.....J	10...OUTPUT 7+
GND.....K	11...+22VOLTS
OUTPUT 7 -.....L	12...REMOTE GAIN
N.C.....M	13...-22VOLTS
REMOTE GAIN (+5v).....N	14...N.C.
N.C.... O	15...GND